

8	7	6	5	4	3	2	1
Material Code	specification 747.7×442.3×9.5mm-V1.0			LOGO	REV.	Date	Changes
				△			
				△			
				△			

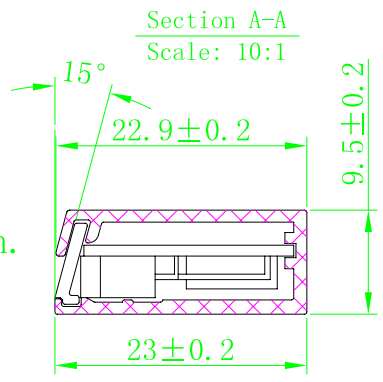
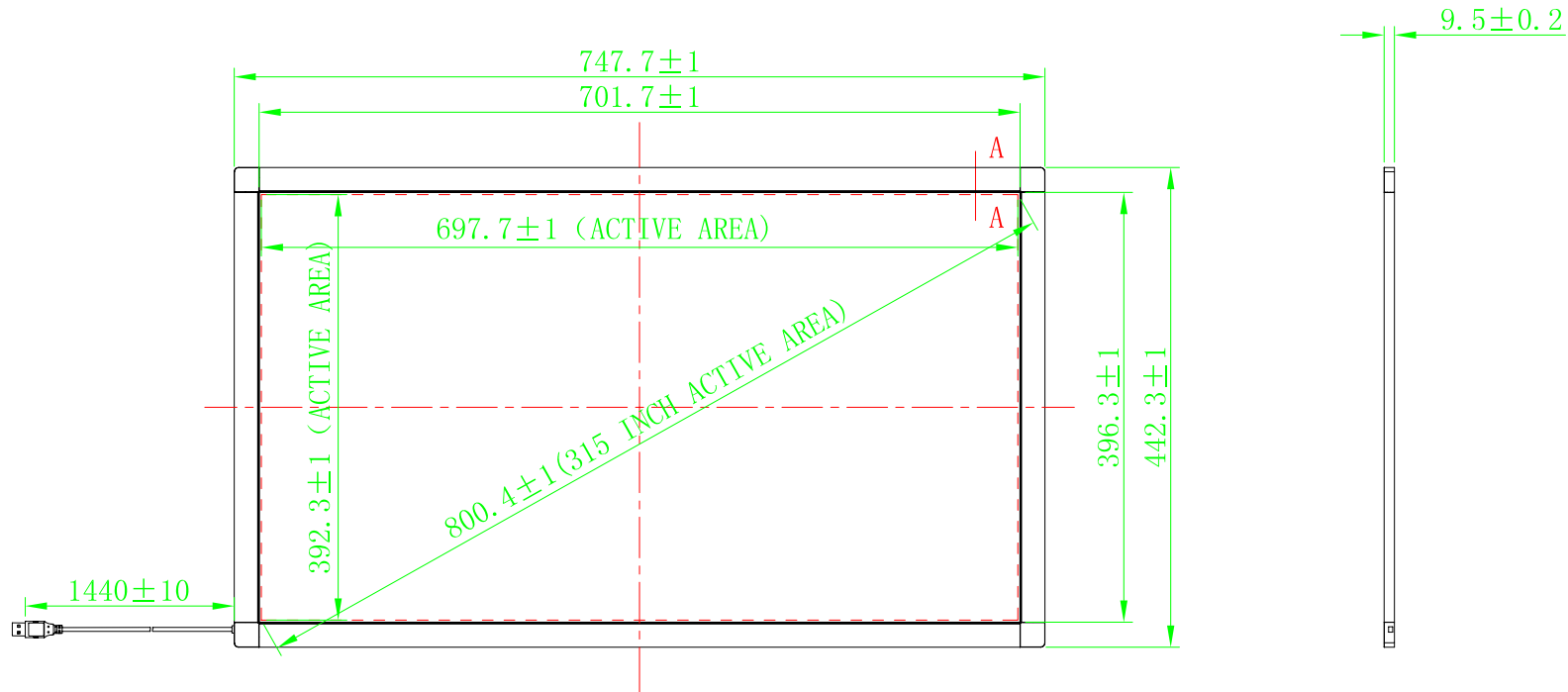

Remarks:
1. Reference design: AU Screen.
2. The product is without the glass.

TOLERANCES (UNLESS OTHERWISE STATED)	
DECIMALS	ANGLES ±0.5°
>2000mm	±2.00mm
1600<X≤2000mm	±1.20mm
1200<X≤1600mm	±0.80mm
800<X≤1200mm	±0.50mm
400<X≤800mm	±0.40mm
120<X≤400mm	±0.30mm
30<X≤120mm	±0.20mm
≤30mm	±0.10mm

THIRD ANGLE PROJECTION

A1Touch Solution BV

MODEL NO.	AO-TFT32-IR-10-USB-PNB			NOTES:
PART No.	1020152792	SCALE	1:1	
PART NAME	Product structure diagram	REV.	1.0	
UNIT	mm	SIZE	FREE	
MATERIAL		SHEET	1/1	
DRAWN			CHK' D	
CHK' D			APP' D	